

Q.1 – Q.25 carry one mark each.

Q1. The eigen values of a skew-symmetric matrix are

- (A) Always zero (C) Either zero or pure imaginary
 (B) Always pure imaginary (D) Always real

Q2. The trigonometric Fourier series for the waveform $f(t)$ shown below contains

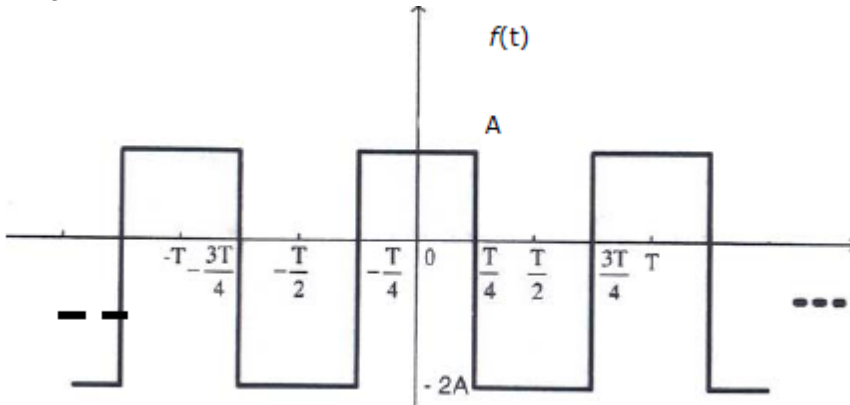

- (A) Only cosine terms and zero value for the dc component
 (B) Only cosine terms and a positive value for the dc component
 (C) Only cosine terms and a negative value for the dc component
 (D) Only sine terms and a negative value for the dc component

Q3. A function $n(x)$ satisfies the differential equation $\frac{d^2 n(x)}{dx^2} - \frac{n(x)}{L^2} = 0$ where L is a constant. The boundary conditions are: $n(0) = K$ and $n(\infty) = 0$. The solution to this equation is

- (A) $n(x) = K \exp(x/L)$
 (B) $n(x) = K \exp(-x/\sqrt{L})$
 (C) $n(x) = K^2 \exp(-x/L)$
 (D) $n(x) = K \exp(-x/L)$

Q4. For the two-port network shown below, the short-circuit admittance parameter matrix is

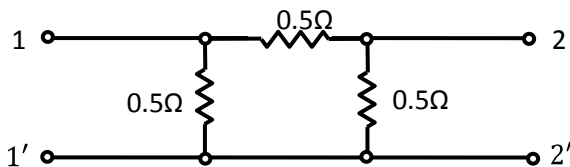

- (A) $\begin{bmatrix} 4 & -2 \\ -2 & 4 \end{bmatrix} S$

- (B) $\begin{bmatrix} 1 & -0.5 \\ -0.5 & 1 \end{bmatrix} \text{S}$
- (C) $\begin{bmatrix} 1 & 0.5 \\ 0.5 & 1 \end{bmatrix} \text{S}$
- (D) $\begin{bmatrix} 4 & 2 \\ 2 & 4 \end{bmatrix} \text{S}$

- Q5. For a parallel RLC circuit, which one of the following statements is NOT correct?
- (A) The bandwidth of the circuit decreases if R is increased
- (B) The bandwidth of the circuit remains same if L is increased
- (C) At resonance, input impedance is a real quantity
- (D) At resonance, the magnitude of input impedance attains its minimum value
- Q6. At room temperature, a possible value for the mobility of electrons in the inversion layer of a silicon n-channel MOSFET is
- (A) $450 \text{ cm}^2/\text{V-s}$
- (B) $1350 \text{ cm}^2/\text{V-s}$
- (C) $1800 \text{ cm}^2/\text{V-s}$
- (D) $3600 \text{ cm}^2/\text{V-s}$
- Q7. Thin gate oxide in a CMOS process is preferably grown using
- (A) wet oxidation
- (B) dry oxidation
- (C) epitaxial deposition
- (D) ion implantation
- Q8. In the silicon BJT circuit shown below, assume that the emitter area of transistor Q1 is half that of transistor Q2.

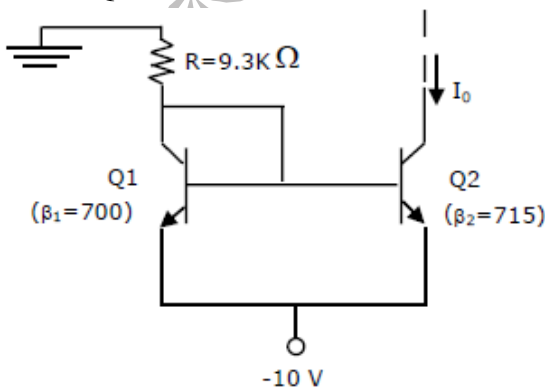

The value of current I_O is approximately

- (A) 0.5 mA (C) 9.3 mA
 (B) 2 mA (D) 15 mA

Q9. The amplifier circuit shown below uses a silicon transistor. The capacitors C_C and C_E can be assumed to be short at signal frequency and the effect of output resistance r_o can be ignored. If C_E is disconnected from the circuit, which one of the following statements is TRUE?

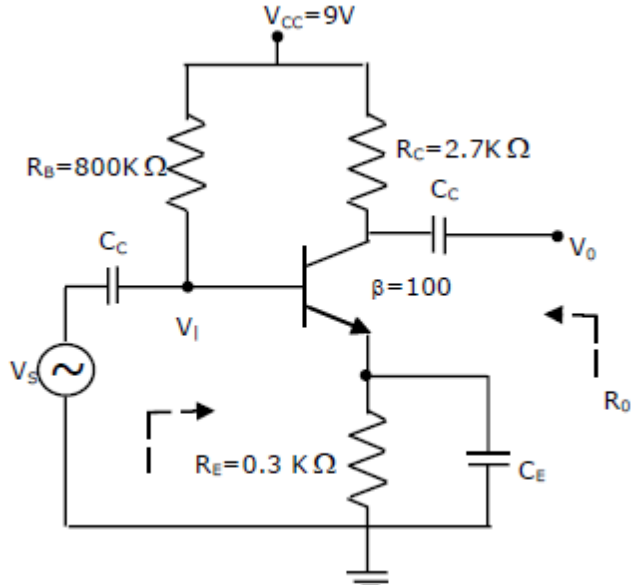

- (A) The input resistance R_i increases and the magnitude of voltage gain A_V decreases
 (B) The input resistance R_i decreases and the magnitude of voltage gain A_V increases
 (C) Both input resistance R_i and the magnitude of voltage gain A_V decrease
 (D) Both input resistance R_i and the magnitude of voltage gain A_V increase

Q10. Assuming the OP-AMP to be ideal, the voltage gain of the amplifier shown below is

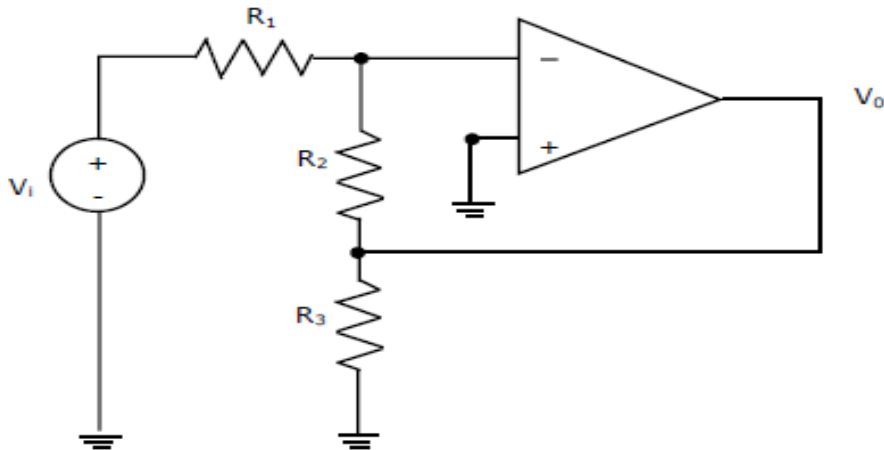

- (A) $-\frac{R_2}{R_1}$
 (B) $-\frac{R_3}{R_1}$
 (C) $-\left(\frac{R_2 || R_3}{R_1}\right)$
 (D) $-\left(\frac{R_2 + R_3}{R_1}\right)$

Q11. Match the logic gates in **Column A** with their equivalents in **Column B**.

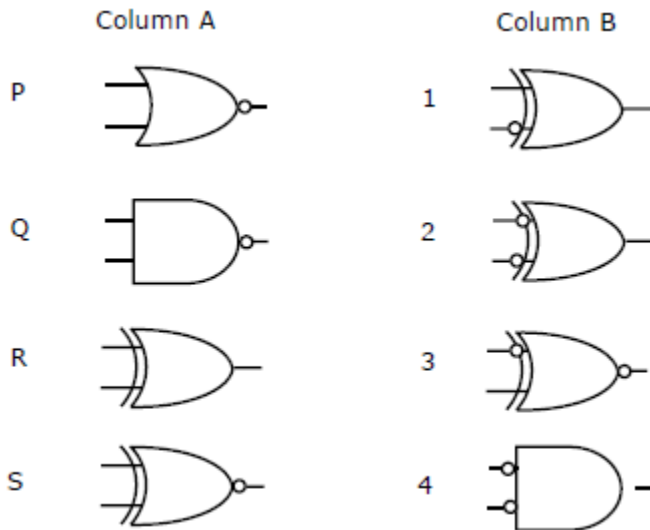

- (A) P-2, Q-4, R-1, S-3
 (B) P-4, Q-2, R-1, S-3
 (C) P-2, Q-4, R-3, S-1
 (D) P-4, Q-2, R-3, S-1

Q12. For the output F to be 1 in the logic circuit shown, the input combination should be

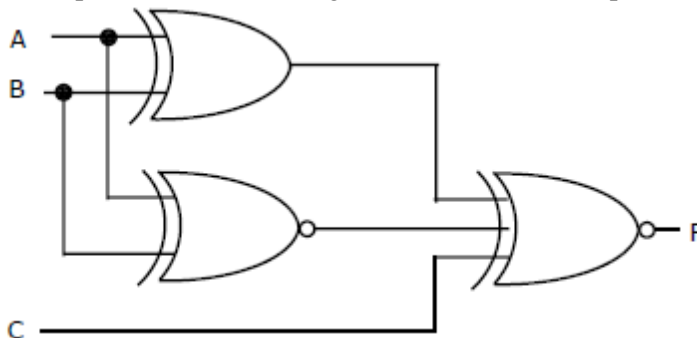

- (A) A=1, B=1, C=0
- (B) A=1, B=0, C=0
- (C) A=0, B=1, C=0
- (D) A=0, B=0, C=1

Q13. In the circuit shown, the device connected to Y5 can have address in the range

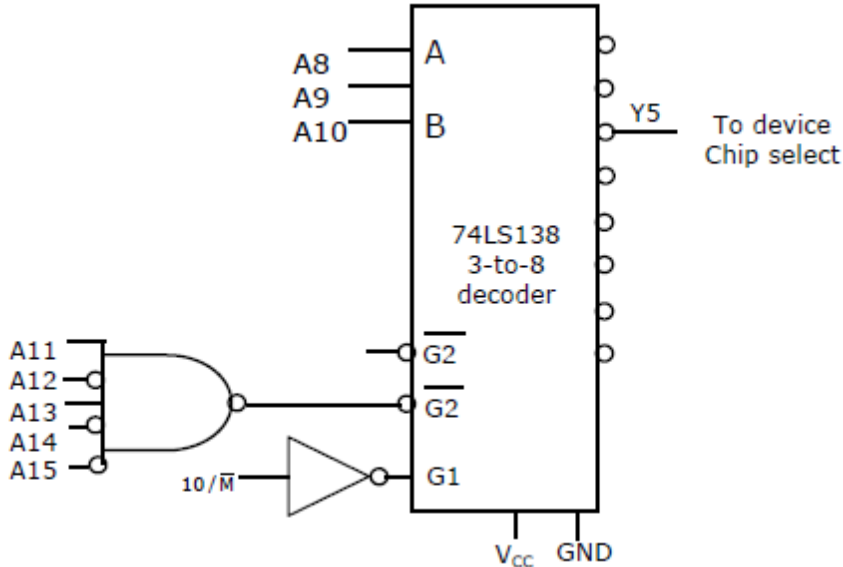

- (A) 2000–20FF
- (B) 2D00–2DFF
- (C) 2E00–2EFF
- (D) FD00–FDFF

Q14. Consider the z-transform $X(z) = 5z^2 + 4z^{-1} + 3$; $0 < |z| < \infty$. The inverse z-transform $x[n]$ is

- (A) $5 \delta[n + 2] + 3 \delta[n] + 4 \delta[n - 1]$
- (B) $5 \delta[n - 2] + 3 \delta[n] + 4 \delta[n + 1]$
- (C) $5 u[n + 2] + 3 u[n] + 4 u[n - 1]$
- (D) $5 u[n - 2] + 3 u[n] + 4 u[n + 1]$

Q15. Two discrete time systems with impulse responses $h_1[n] = \delta[n - 1]$ and $h_2[n] = \delta[n - 2]$ are connected in cascade. The overall impulse response of the cascaded system is

- (A) $\delta[n - 1] + \delta[n - 2]$
- (B) $\delta[n - 4]$
- (C) $\delta[n - 3]$
- (D) $\delta[n - 1] \delta[n - 2]$

- Q16. For an N-point FFT algorithm with $N = 2^m$, which one of the following statements is TRUE?
- (A) It is not possible to construct a signal flow graph with both input and output in normal order
 - (B) The number of butterflies in the m^{th} stage is N/m
 - (C) In-place computation requires storage of only $2N$ node data
 - (D) Computation of a butterfly requires only one complex multiplication

Q17. The transfer function $Y(s)/R(s)$ of the system shown is

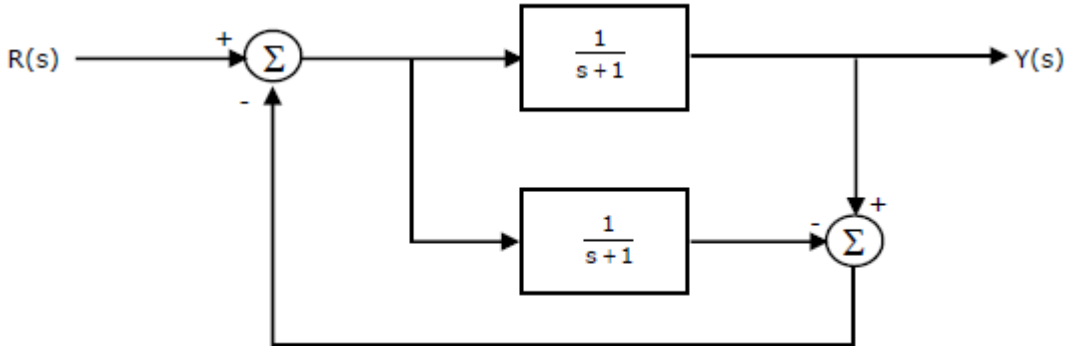

- (A) 0
 - (B) $\frac{1}{s+1}$
 - (C) $\frac{2}{s+1}$
 - (D) $\frac{2}{s+3}$
- Q18. A system with the transfer function $\frac{Y(s)}{X(s)} = \frac{s}{s+p}$ has an output $y(t) = \cos\left(2t - \frac{\pi}{3}\right)$ for the input signal $X(t) = p \cos\left(2t - \frac{\pi}{2}\right)$. Then, the system parameter 'p' is
- (A) $\sqrt{3}$
 - (B) $\frac{2}{\sqrt{3}}$
 - (C) 1
 - (D) $\frac{\sqrt{3}}{2}$
- Q19. For the asymptotic Bode magnitude plot shown below, the system transfer function can be

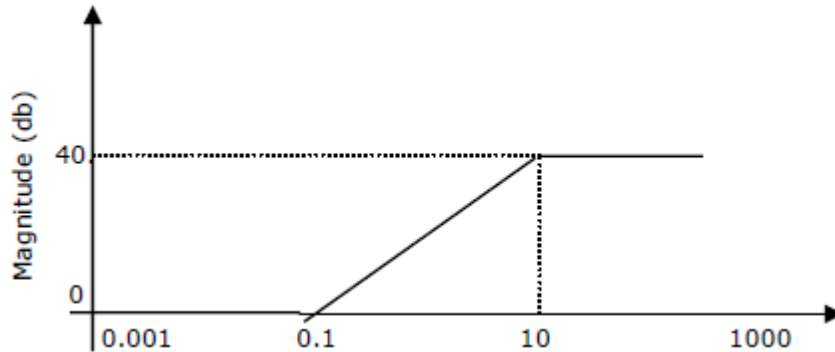

- (A) $\frac{10s+1}{0.1s+1}$
 (B) $\frac{100s+1}{0.1s+1}$
 (C) $\frac{100s}{10s+1}$
 (D) $\frac{0.1s+1}{10s+1}$

Q20. Suppose that the modulating signal is $m(t) = 2 \cos(2\pi f_m t)$ and the carrier signal is $x_c(t) = A_c \cos(2\pi f_c t)$. Which one of the following is a conventional AM signal without over-modulation?

- (A) $x(t) = A_c m(t) \cos(2\pi f_c t)$
 (B) $x(t) = A_c [1 + m(t)] \cos(2\pi f_c t)$
 (C) $x(t) = A_c \cos(2\pi f_c t) + \frac{A_c}{4} m(t) \cos(2\pi f_c t)$
 (D) $x(t) = A_c \cos(2\pi f_m t) \cos(2\pi f_c t) + A_c \sin(2\pi f_m t) \sin(2\pi f_c t)$

Q21. Consider an angle modulated signal

$x(t) = 6 \cos[2\pi \times 10^6 t + 2 \sin(8000\pi t) + 4 \cos(8000\pi t)]$ V. The average power of $x(t)$ is

- (A) 10 W
 (B) 18 W
 (C) 20 W
 (D) 28 W

Q22. If the scattering matrix $[S]$ of a two port network is

$$[S] = \begin{bmatrix} 0.2 \angle 0^\circ & 0.9 \angle 90^\circ \\ 0.9 \angle 90^\circ & 0.1 \angle 90^\circ \end{bmatrix}$$

then the network is

- (A) lossless and reciprocal
 (B) lossless but not reciprocal

- (C) not lossless but reciprocal
- (D) neither lossless nor reciprocal

Q23. A transmission line has a characteristic impedance of 50Ω and a resistance of $0.1 \Omega/m$. If the line is distortionless, the attenuation constant (in Np/m) is

- (A) 500
- (B) 5
- (C) 0.014
- (D) 0.002

Q24. Consider the pulse shape $s(t)$ as shown. The impulse response $h(t)$ of the filter matched to this pulse is

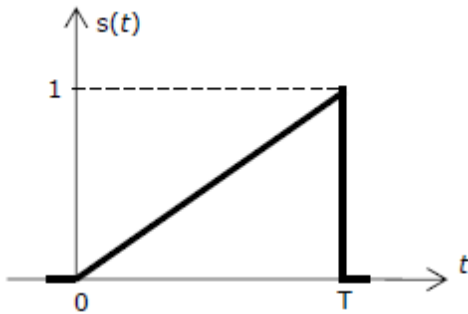

(A)

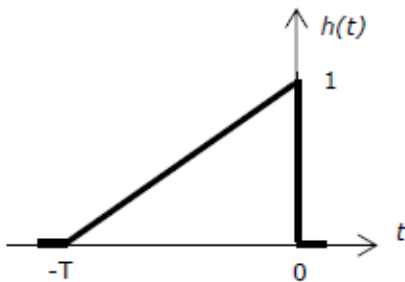

(C)

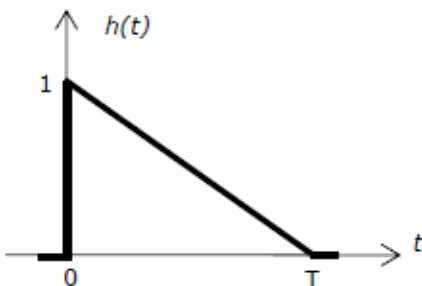

(B)

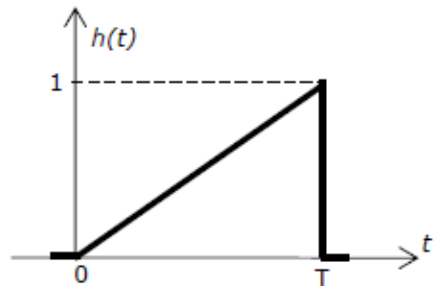

(D)

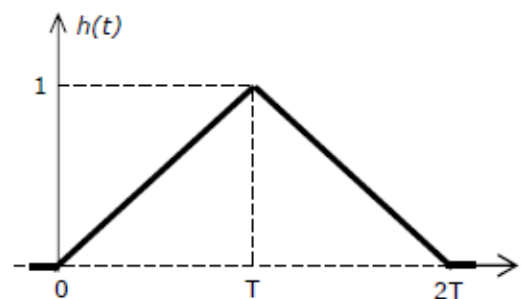

Q25. The electric field component of a time harmonic plane EM wave travelling in a nonmagnetic lossless dielectric medium has an amplitude of 1 V/m. If the relative permittivity of the medium is 4, the magnitude of the time-average power density vector (in W/m^2) is

- (A) $\frac{1}{30\pi}$ (C) $\frac{1}{120\pi}$
 (B) $\frac{1}{60\pi}$ (D) $\frac{1}{240\pi}$

Q.26 – Q.55 carry two marks each.

Q26. If $e^y = x^{\frac{1}{x}}$, then y has a

- (A) maximum at $x = e$ (C) maximum at $x = e^{-1}$
 (B) minimum at $x = e$ (D) minimum at $x = e^{-1}$

Q27. A fair coin is tossed independently four times. The probability of the event “the number of times heads show up is more than the number of times tails show up” is

- (A) $\frac{1}{16}$
 (B) $\frac{1}{8}$
 (C) $\frac{1}{4}$
 (D) $\frac{5}{16}$

Q28. If $\vec{A} = xy \hat{a}_x + x^2 \hat{a}_y$, then $\oint_C \vec{A} \cdot d\vec{l}$ over the path shown in the figure is

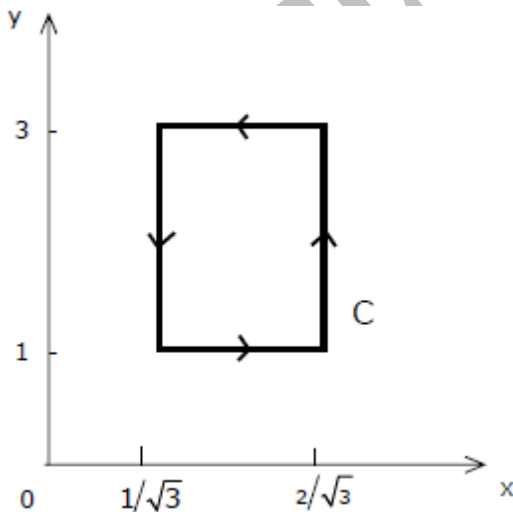

- (A) 0
- (B) $\frac{2}{\sqrt{3}}$
- (C) 1
- (D) $2\sqrt{3}$

Q29. The residues of a complex function $X(z) = \frac{1-2z}{z(z-1)(z-2)}$ at its poles are

- (A) $\frac{1}{2}, -\frac{1}{2}$ and 1
- (B) $\frac{1}{2}, \frac{1}{2}$ and -1
- (C) $\frac{1}{2}, 1$ and $-\frac{3}{2}$
- (D) $\frac{1}{2}, -1$ and $\frac{3}{2}$

Q30. Consider a differential equation $\frac{dy(x)}{dx} - y(x) = x$ with the initial condition $y(0) = 0$. Using Euler's first order method with a step size of 0.1, the value of $y(0.3)$ is

- (A) 0.01
- (B) 0.031
- (C) 0.0631
- (D) 0.1

Q31. Given $f(t) = L^{-1} \left[\frac{3s+1}{s^3+4s^2+(K-3)s} \right]$. If $\lim_{t \rightarrow \infty} f(t) = 1$, then the value of K is

- (A) 1
- (B) 2
- (C) 3
- (D) 4

Q32. In the circuit shown, the switch S is open for a long time and is closed at $t = 0$. The current $i(t)$ for $t \geq 0^+$ is

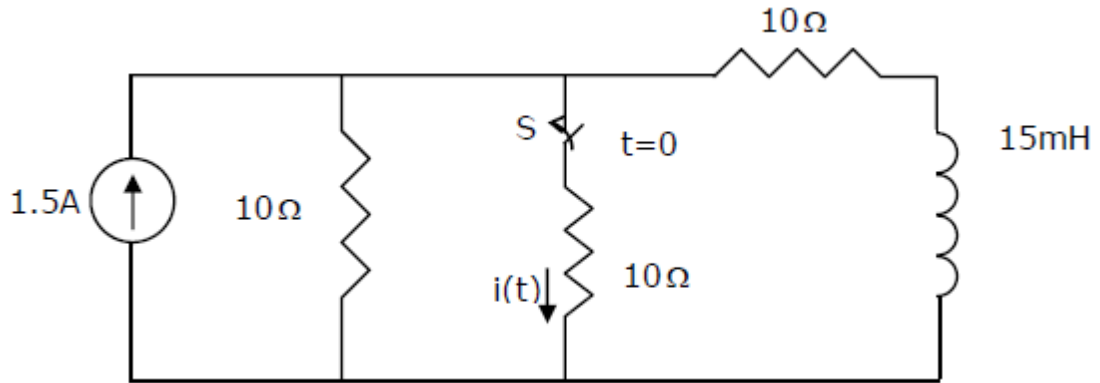

- (A) $i(t) = 0.5 - 0.125e^{-1000t} A$
 (B) $i(t) = 1.5 - 0.125e^{-1000t} A$
 (C) $i(t) = 0.5 - 0.5e^{-1000t} A$
 (D) $i(t) = 0.375e^{-1000t} A$

Q33. The current I in the circuit shown is

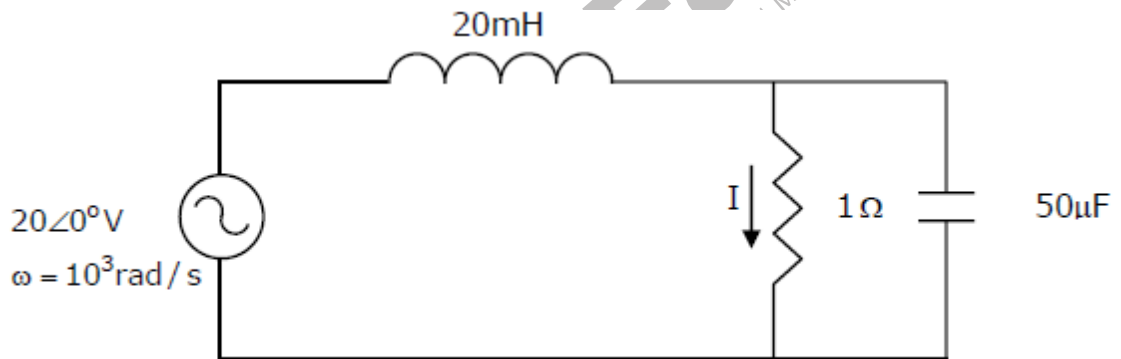

- (A) $-j1 A$
 (B) $j1 A$
 (C) $0 A$
 (D) $20 A$

Q34. In the circuit shown, the power supplied by the voltage source is

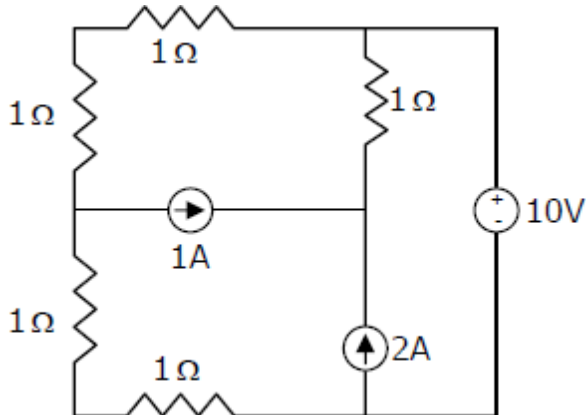

- (A) 0 W
- (B) 5 W
- (C) 10 W
- (D) 100 W

Q35. In a uniformly doped BJT, assume that N_E , N_B and N_C are the emitter, base and collector dopings in atoms/cm³, respectively. If the emitter injection efficiency of the BJT is close to unity, which one of the following conditions is TRUE?

- (A) $N_E = N_B = N_C$
- (B) $N_E \gg N_B$ and $N_B > N_C$
- (C) $N_E = N_B$ and $N_B < N_C$
- (D) $N_E < N_B < N_C$

Q36. Compared to a p-n junction with $N_A = N_D = 10^{14}/\text{cm}^3$, which one of the following statements is TRUE for a p-n junction with $N_A = N_D = 10^{20}/\text{cm}^3$?

- (A) Reverse breakdown voltage is lower and depletion capacitance is lower
- (B) Reverse breakdown voltage is higher and depletion capacitance is lower
- (C) Reverse breakdown voltage is lower and depletion capacitance is higher
- (D) Reverse breakdown voltage is higher and depletion capacitance is higher

Q37. Assuming that all flips-flops are in reset condition initially, the count sequence observed at Q_A in the circuit shown is

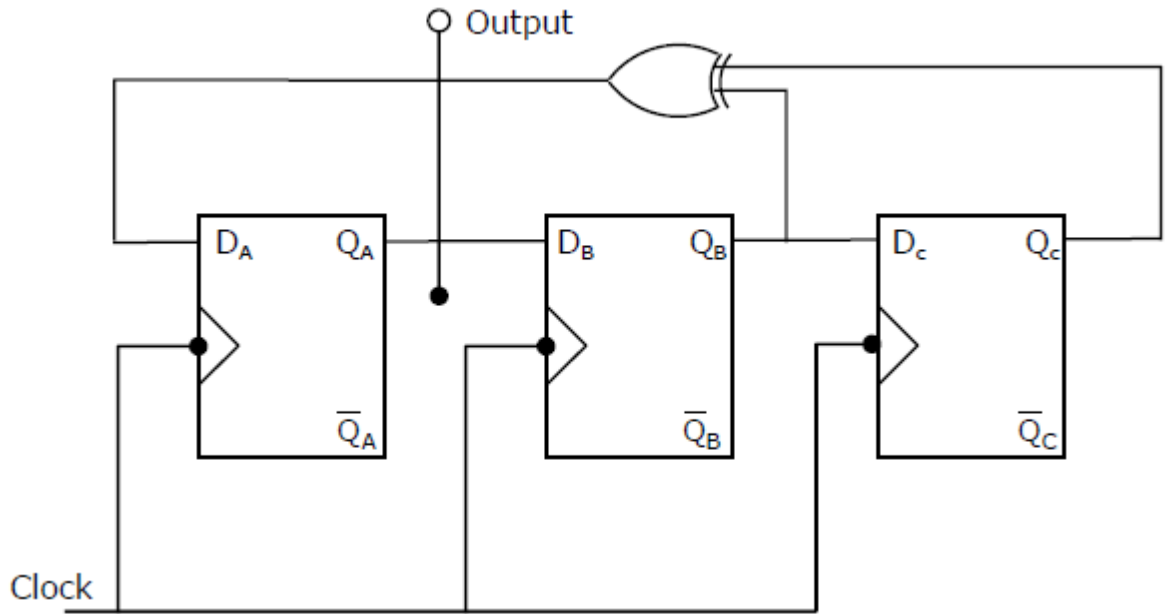

- (A) 0010111...
- (B) 0001011...
- (C) 0101111...
- (D) 0110100...

Q38. The transfer characteristic for the precision rectifier circuit shown below is (assume ideal OP-AMP and practical diodes)

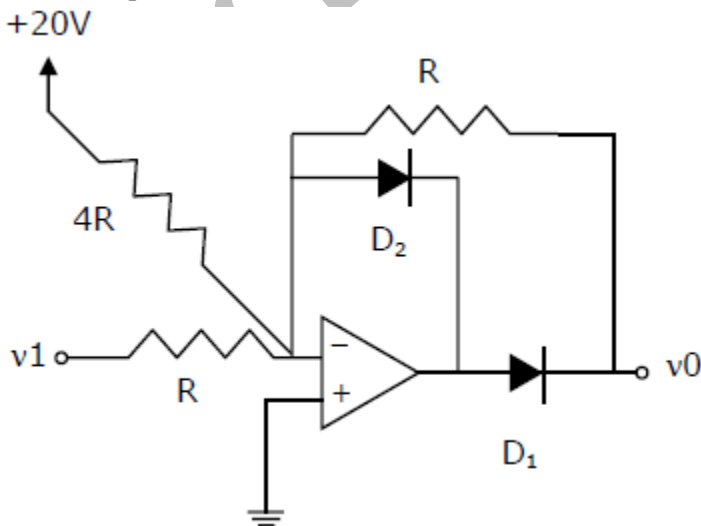

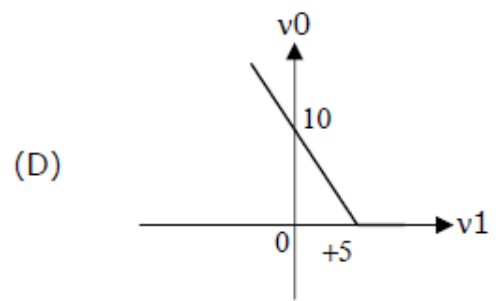
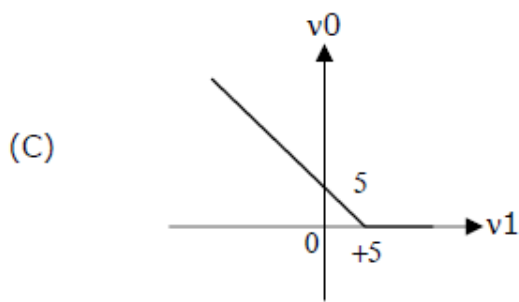
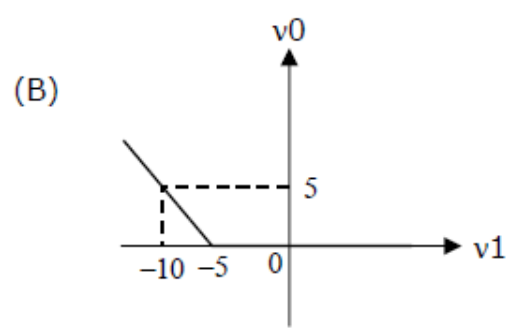
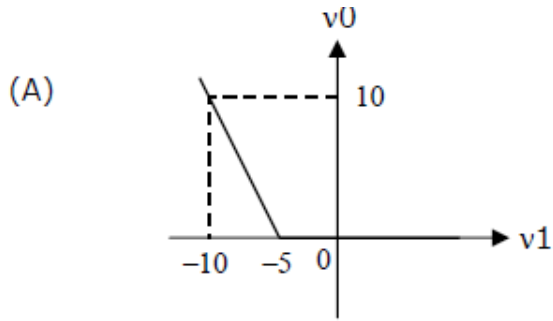

Q39. The Boolean function realized by the logic circuit shown is

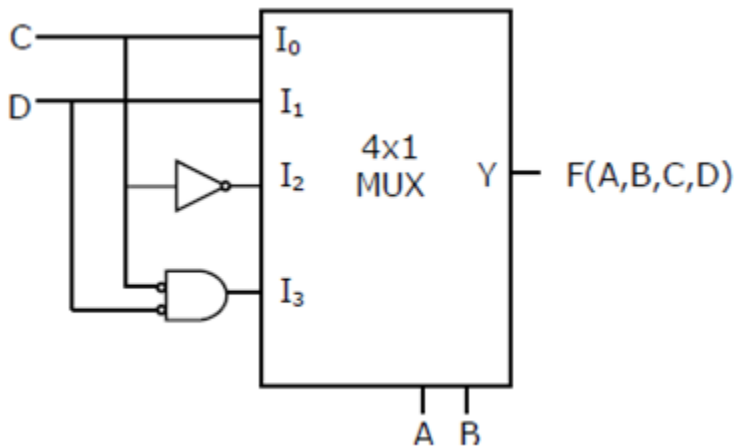

- (A) $F = \sum m(0, 1, 3, 5, 9, 10, 14)$
- (B) $F = \sum m(2, 3, 5, 7, 8, 12, 13)$
- (C) $F = \sum m(1, 2, 4, 5, 11, 14, 15)$
- (D) $F = \sum m(2, 3, 5, 7, 8, 9, 12)$

Q40. For the 8085 assembly language program given below, the content of the accumulator after the execution of the program is

3000	MVI	A,	45H
3002	MOV	B,	A
3003	STC		
3004	CMC		
3005	RAR		
3006	XRA	B	

- (A) 00H
- (B) 45H
- (C) 67H
- (D) E7H

Q41. A continuous time LTI system is described by

$$\frac{d^2y(t)}{dt^2} + 4\frac{dy(t)}{dt} + 3y(t) = 2\frac{dx(t)}{dt} + 4x(t)$$

Assuming zero initial conditions, the response $y(t)$ of the above system for the input $x(t) = e^{-2t}u(t)$ is given by

- (A) $(e^t - e^{3t})u(t)$
- (B) $(e^{-t} - e^{-3t})u(t)$
- (C) $(e^{-t} + e^{-3t})u(t)$
- (D) $(e^t + e^{3t})u(t)$

Q42. The transfer function of a discrete time LTI system is given by

$$H(z) = \frac{2 - \frac{3}{4}z^{-1}}{1 - \frac{3}{4}z^{-1} + \frac{1}{8}z^{-2}}$$

Consider the following statements:

- S1: The system is stable and causal for ROC: $|z| > \frac{1}{2}$
- S2: The system is stable but not causal for ROC: $|z| < \frac{1}{4}$
- S3: The system is neither stable nor causal for ROC: $\frac{1}{4} < |z| < \frac{1}{2}$

Which one of the following statements is valid?

- (A) Both S1 and S2 are true
- (B) Both S2 and S3 are true
- (C) Both S1 and S3 are true
- (D) S1, S2 and S3 are all true

Q43. The Nyquist sampling rate for the signal $s(t) = \frac{\sin(500\pi t)}{\pi t} \times \frac{\sin(700\pi t)}{\pi t}$ is given by

- (A) 400 Hz
- (B) 600 Hz
- (C) 1200 Hz
- (D) 1400 Hz

Q44. A unity negative feedback closed loop system has a plant with the transfer function $G(s) = \frac{1}{s^2 + 2s + 2}$ and a controller $G_c(s)$ in the feedforward path. For a unit step input, the transfer function of the controller that gives minimum steady state error is

- (A) $G_c(s) = \frac{s+1}{s+2}$
- (B) $G_c(s) = \frac{s+2}{s+1}$
- (C) $G_c(s) = \frac{(s+1)(s+4)}{(s+2)(s+3)}$
- (D) $G_c(s) = 1 + \frac{2}{s} + 3s$

Q45. $X(t)$ is a stationary process with the power spectral density $S_x(f) > 0$ for all f . The process is passed through a system shown below.

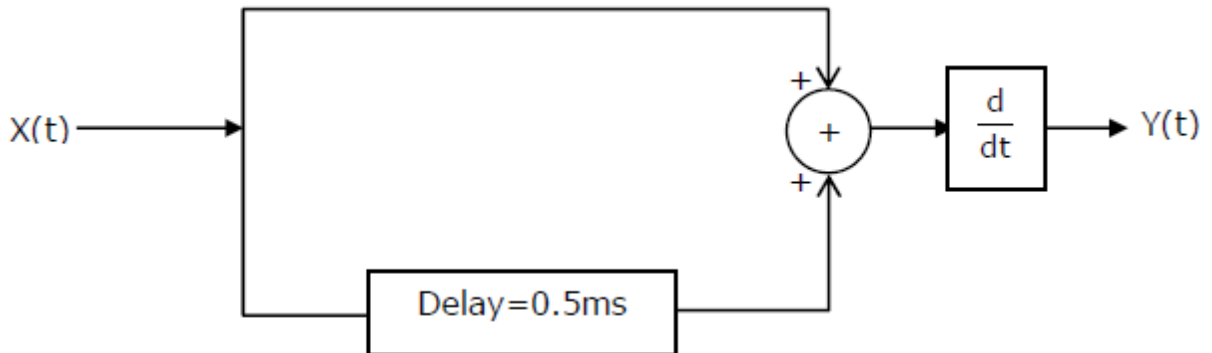

Let $S_y(f)$ be the power spectral density of $Y(t)$. Which one of the following statements is correct?

- (A) $S_y(f) > 0$ for all f
- (B) $S_y(f) = 0$ for $|f| > 1$ kHz
- (C) $S_y(f) = 0$ for $f = nf_0$, $f_0 = 2$ kHz, n any integer
- (D) $S_y(f) = 0$ for $f = (2n + 1)f_0$, $f_0 = 1$ kHz, n any integer

Q46. A plane wave having the electric field component $\vec{E}_i = 24 \cos(3 \times 10^8 t - \beta y) \hat{a}_z$ V/m and traveling in free space is incident normally on a lossless medium with $\mu = \mu_0$ and $\epsilon = 9\epsilon_0$ which occupies the region $y \geq 0$. The reflected magnetic field component is given by

- (A) $\frac{1}{10\pi} \cos(3 \times 10^8 t + y) \hat{a}_x$ A/m
- (B) $\frac{1}{20\pi} \cos(3 \times 10^8 t + y) \hat{a}_x$ A/m
- (C) $-\frac{1}{20\pi} \cos(3 \times 10^8 t + y) \hat{a}_x$ A/m
- (D) $-\frac{1}{10\pi} \cos(3 \times 10^8 t + y) \hat{a}_x$ A/m

Q47. In the circuit shown, all the transmission line sections are lossless. The Voltage Standing Wave Ratio (VSWR) on the 60Ω line is

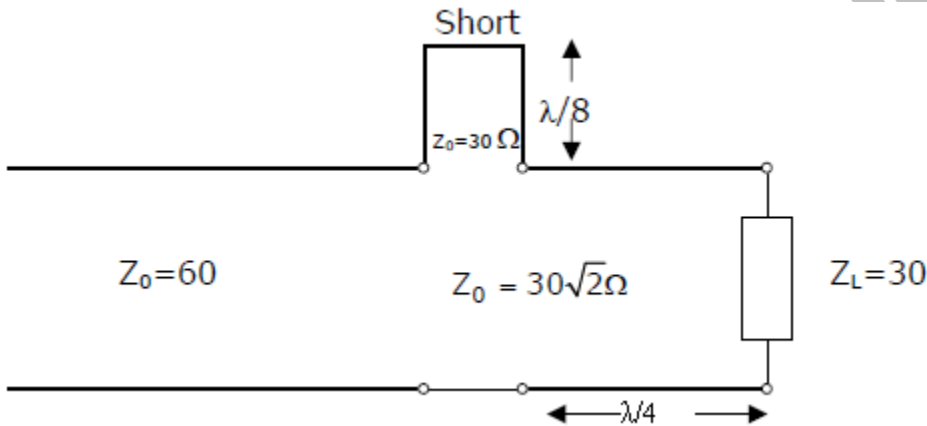

- (A) 1.00
- (B) 1.64
- (C) 2.50
- (D) 3.00

Common Data Questions

Common Data for Questions 48 and 49:

Consider the common emitter amplifier shown below with the following circuit parameters:

$\beta = 100, g_m = 0.3861$ A/V, $r_o = \infty, r_{\pi} = 259 \Omega, R_s = 1$ kΩ, $R_B = 93$ kΩ, $R_C = 250 \Omega, R_L = 1$ kΩ, $C_1 = \infty$ and $C_2 = 4.7 \mu F$.

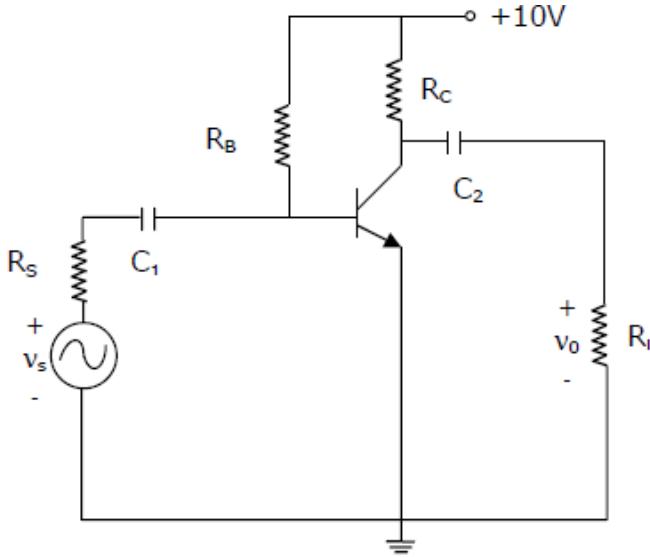

Q48. The resistance seen by the source v_s is

- (A) 258 Ω
- (B) 1258 Ω
- (C) 93 k Ω
- (D) ∞

Q49. The lower cut-off frequency due to C_2 is

- (A) 33.9 Hz
- (B) 27.1 Hz
- (C) 13.6 Hz
- (D) 16.9 Hz

Common Data for Questions 50 and 51:

The signal flow graph of a system is shown below.

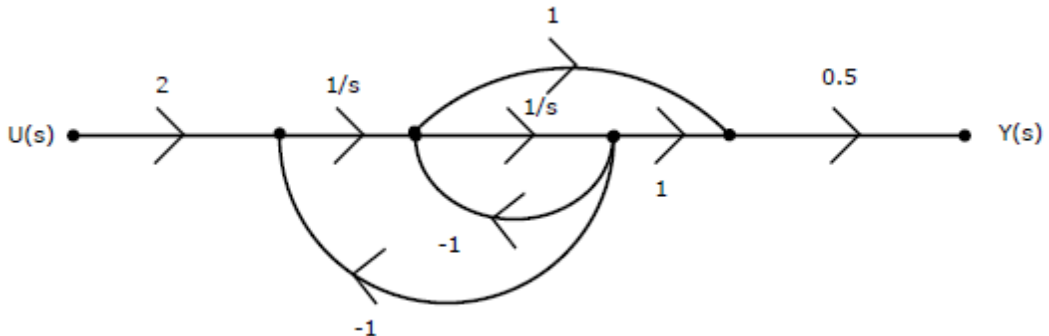

Q50. The state variable representation of the system can be

$$(A) \dot{x} = \begin{bmatrix} 1 & 1 \\ -1 & 0 \end{bmatrix} x + \begin{bmatrix} 0 \\ 2 \end{bmatrix} u$$

$$y = [0 \quad 0.5]x$$

$$(B) \dot{x} = \begin{bmatrix} -1 & 1 \\ -1 & 0 \end{bmatrix} x + \begin{bmatrix} 0 \\ 2 \end{bmatrix} u$$

$$y = [0 \quad 0.5]x$$

$$(C) \dot{x} = \begin{bmatrix} 1 & 1 \\ -1 & 0 \end{bmatrix} x + \begin{bmatrix} 0 \\ 2 \end{bmatrix} u$$

$$y = [0.5 \quad 0.5]x$$

$$(D) \dot{x} = \begin{bmatrix} -1 & 1 \\ -1 & 0 \end{bmatrix} x + \begin{bmatrix} 0 \\ 2 \end{bmatrix} u$$

$$y = [0.5 \quad 0.5]x$$

Q51. The transfer function of the system is

$$(A) \frac{s+1}{s^2+1}$$

$$(B) \frac{s-1}{s^2+1}$$

$$(C) \frac{s+1}{s^2+s+1}$$

$$(D) \frac{s-1}{s^2+s+1}$$

Linked Answer Questions

Statement for Linked Answer Questions 52 and 53:

The silicon sample with unit cross-sectional area shown below is in thermal equilibrium. The following information is given: $T = 300$ K, electronic charge = 1.6×10^{-19} C, thermal voltage = 26 mV and electron mobility = $1350 \text{ cm}^2/\text{V} - \text{s}$

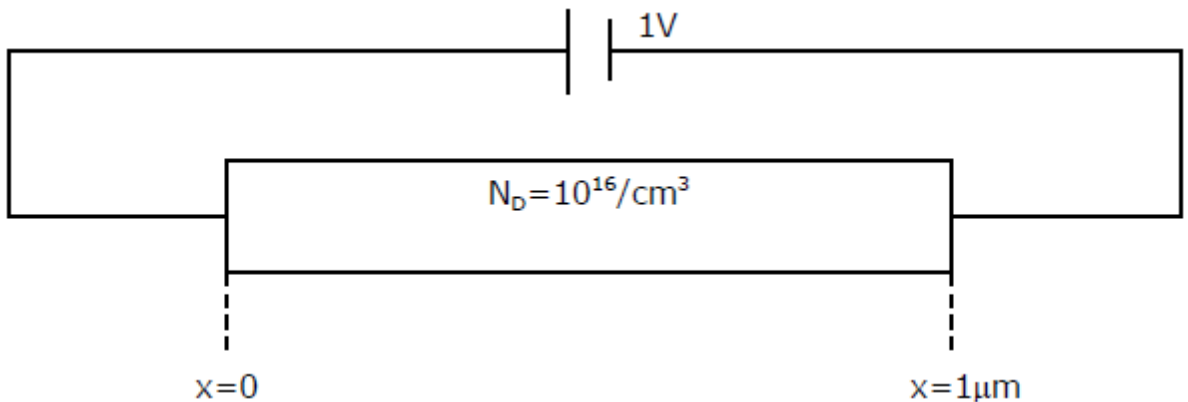

Q52. The magnitude of the electric field at $x = 0.5 \mu\text{m}$ is

- (A) 1 kV/cm
- (B) 5 kV/cm
- (C) 10 kV/cm
- (D) 26 kV/cm

Q53. The magnitude of the electron drift current density at $x = 0.5 \mu\text{m}$ is

- (A) $2.16 \times 10^4 \text{ A/cm}^2$
- (B) $1.08 \times 10^4 \text{ A/cm}^2$
- (C) $4.32 \times 10^3 \text{ A/cm}^2$
- (D) $6.48 \times 10^2 \text{ A/cm}^2$

Statement for Linked Answer Questions 54 and 55:

Consider a baseband binary PAM receiver shown below. The additive channel noise $n(t)$ is white with power spectral density $S_N(f) = \frac{N_0}{2} = 10^{-20} \text{ W/Hz}$. The low-pass filter is ideal with unity gain and cutoff frequency 1 MHz. Let Y_k represent the random variable $y(t_k)$.

$Y_k = N_k$ if transmitted bit $b_k = 0$

$Y_k = a + N_k$ if transmitted bit $b_k = 1$

where N_k represents the noise sample value. The noise sample has a probability density function, $P_{N_k}(n) = 0.5 \alpha e^{-\alpha|n|}$ (This has mean zero and variance $2/\alpha^2$). Assume transmitted bits to be equiprobable and threshold z is set to $a/2 = 10^{-6} \text{ V}$.

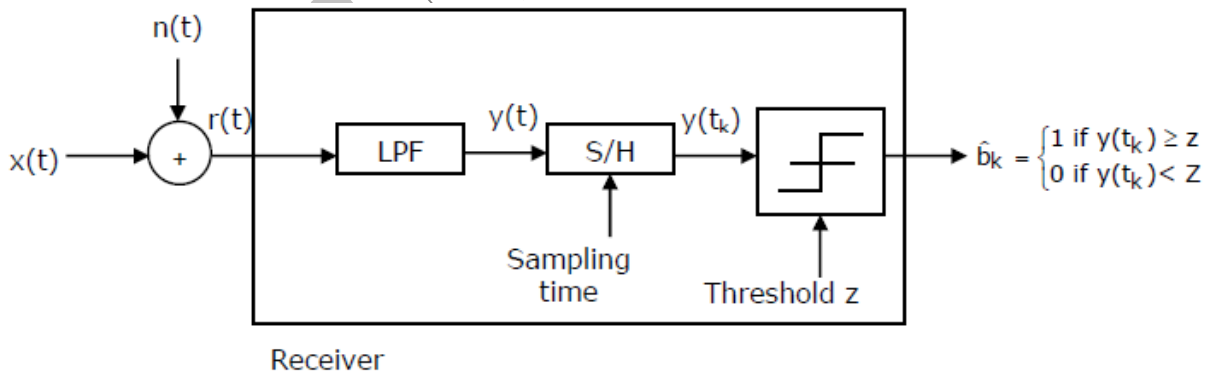

Q54. The value of the parameter α (in V^{-1}) is

- (A) 10^{10}
- (B) 10^7
- (C) 1.414×10^{-10}
- (D) 2×10^{-20}

Q55. The probability of bit error is

- (A) $0.5 \times e^{-3.5}$
- (B) $0.5 \times e^{-5}$
- (C) $0.5 \times e^{-7}$
- (D) $0.5 \times e^{-10}$

General Aptitude (GA) Questions

Q.56 – Q.60 carry one mark each.

Q56. Which of the following options is the closest in meaning to the word below:

Circuitous

- (A) cyclic
- (B) indirect
- (C) confusing
- (D) crooked

Q57. The question below consists of a pair of related words followed by four pairs of words. Select the pair that best expresses the relation in the original pair.

Unemployed: Worker

- (A) fallow : land
- (B) unaware : sleeper
- (C) wit : jester
- (D) renovated : house

Q58. Choose the most appropriate word from the options given below to complete the following sentence:

If we manage to _____ our natural resources, we would leave a better planet for our children.

- (A) uphold
- (B) restrain
- (C) cherish
- (D) conserve

Q59. Choose the most appropriate word from the options given below to complete the following sentence:

His rather casual remarks on politics _____ his lack of seriousness about the subject.

- (A) masked
- (B) belied
- (C) betrayed

(D) suppressed

Q60. 25 persons are in a room. 15 of them play hockey, 17 of them play football and 10 of them play both hockey and football. Then the number of persons playing neither hockey nor football is:

- (A) 2
- (B) 17
- (C) 13
- (D) 3

Q.61 – Q.65 carry two marks each.

Q61. Modern warfare has changed from large scale clashes of armies to suppression of civilian populations. Chemical agents that do their work silently appear to be suited to such warfare; and regretfully, there exist people in military establishments who think that chemical agents are useful tools for their cause.

Which of the following statements best sums up the meaning of the above passage;

- (A) Modern warfare has resulted in civil strife.
- (B) Chemical agents are useful in modern warfare.
- (C) Use of chemical agents in warfare would be undesirable.
- (D) People in military establishments like to use chemical agents in war.

Q62. If $137 + 276 = 435$ how must is $731 + 672$?

- (A) 534
- (B) 1403
- (C) 1623
- (D) 1513

Q63. 5 skilled workers can build a wall in 20 days; 8 semi – skilled workers can build a wall in 25 days; 10 unskilled workers can build a wall in 30 days. If team has 2 skilled, 6 semi-skilled and 5 unskilled workers, how long will it take to build the wall?

- (A) 20 days
- (B) 18 days
- (C) 16 days
- (D) 15 days

Q64. Given digits 2, 2, 3, 3, 3, 4, 4, 4, 4 how many distinct 4 digit numbers greater than 3000 can be formed?

- (A) 50
- (B) 51
- (C) 52
- (D) 54

Q65. Hari (H), Gita (G), Irfan (I) and Saira (S) are siblings (i.e. brothers and sisters). All were born on 1st January. The age difference between any two successive siblings (that is born one after another) is less than 3 years. Given the following facts:

- i. Hari's age + Gita's age > Irfan's age + Saira's age
- ii. The age difference between Gita and Saira is 1 year. However, Gita is not the oldest and Saira is not the youngest.
- iii. There are no twins.

In what order were they born (oldest first)?

(A) HSI G

(B) SGHI

(C) IGSH

(D) IHSG

